

1023532110

ENA2100-Double

Mounting Kit for ENA2100-AC

Description

Kit for mounting two ENA2100-AC amplifiers together in a 19-inch rack. The kit is an angle joint.

Technical Dimensions

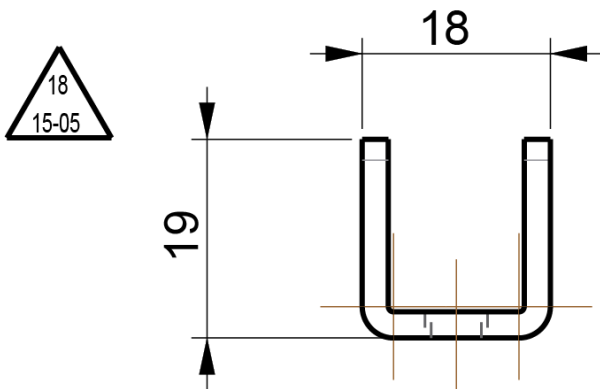
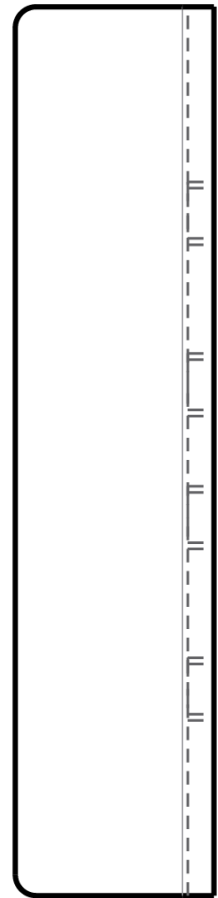
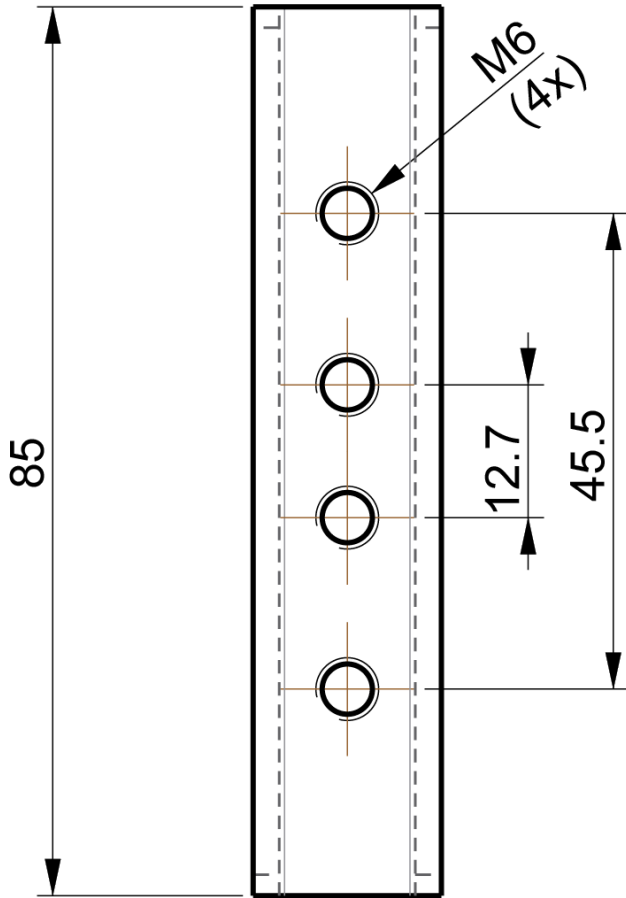

All dimensions in mm

Used With



ENA2100-AC

Exigo Network Amplifier 2 x
100W